

Introduction

Well known as a metal object collection, The Bumiller set also includes an important corpus of Islamic ceramics. According to his personal sensitivity for shape and décor Manfred Bumiller bought more than 400 pieces from the early eighties onward. In that aspect, the compilation is particularly rich and thus this book is dedicated to his 'collector's eye'. The relentless pursuit for new pieces and a certain fidelity to some art dealers resulted in a true homogeneity of the collection. I am aware of the fact that most of the set comes from the art market and therefore may assume a certain dark side, specifically as 'floating' material that is out of context. The selection of 188 objects from the ceramic assemblage of The Bumiller Collection emphasizes the complexity of Islamic ceramic studies as a whole, completing our actual knowledge about city networks, regional and international trade roads and hereinafter the circulation of goods, craftsmen and techniques across Central Asia.

With this work I wish to encourage and contribute to active debates on material from Central Asia. May it serve as a useful tool to anyone interested in Eastern Islamic ceramics. The study of the ceramic corpus that I conducted at the University Museum of Islamic Art between 2011 and 2013 was made possible by Professor Lorenz Korn, chair of Islamic Art and Archaeology at the Institute of Oriental Studies of the Otto-Friedrich-University of Bamberg (Germany).

Indebted to the works of POPE, LANE, SOUSTIEL, GRUBE and WATSON, I want to break ground for a new approach to the study of Islamic ceramics in Museum contexts. Usually written by curators and art historians, catalogues of Islamic ceramics focus on iconography and stylistic developments. Completing the art historical approach with the data of an archaeologist by including shape and size can lead to entirely new perceptions. The size of the objects or the occurrence of large numbers of certain types are barely used as comparative data, although they can help to identify workshops. Technical elements, such as traces of tools, the size of the brushes used for slip painting, defects in the glaze or the direction of firing, are generally not even mentioned, even if obviously recurrent. Fortunately, the profile picture has become standard (WATSON for instance) as it obviously allows further analysis. A technical drawing however makes systematic comparisons easier and delineates technical habits. Since for some well-known types only a few drawn profiles are published (KIANI, GRUBE, GARDIN, WATSON and MASON), I wish to present a useful supplement by providing a complete graphic documentation of all shapes under study.

In my approach I use the archaeological methodology: drawing and classification according to technique (nature of the glaze, range of slips colours and clay material) and shape (typomorphology) in order to bring new arguments into the discussion on date and origin. Decoration and design cannot be the unique criteria for sorting, because sometimes pieces that appear similar at first glance were produced with different tools. I always tried to reconnect the objects under study with archaeological data; when the data were missing I consulted comparative assemblages. Russian, Central Asian and Iranian excavation reports were extensively used. My recent field research in Uzbekistan, Tajikistan, Turkmenistan and Afghanistan also allowed me to use the latest archaeological data from eastern Islamic lands. Personal pictures from regional museums were extensively used, therefore inventory numbers are missing in some cases. Yet the comparative data are unequal in quality and important lacunas still exist regarding Iranian and Afghan medieval pottery.

Geographic labels attached to many of the Iranian types are convenient, that is why they are commonly and widely used by art dealers, collectors as well as researchers since the 1930s. Nevertheless, geographic or town labels such as 'Nishapur', 'Samarkand', 'Gurgan', 'Sari', indicating place of production, need critical consideration, because archaeological evidence regarding the places of production and workshops is still relatively unknown.

Doubtful pieces occur in the most prestigious auctions and collections and show up in old and even recent catalogues. Except for the WATSON publications (1985c, 2004b and 2013) devoted to this aspect within Islamic ceramics studies, fakes and forgeries are still barely considered and may even be considered taboo in this field of study. Without doubt the study of forgeries presents an interest, at least in helping to discard them. But only the study of large series – not that of isolated pieces – can lead to useful results. Only four dubious pieces (BC 4094, 4095, 2414, 018), which may be modern productions, are still included in the present catalogue with a clear mention in the caption. More than 20 pieces of so-called Bamyan wares from The Bumiller Collection were excluded, as many factors reveal them as obvious forgeries. However, the examination and exposure of fakes and forgeries is a chapter of its own. It is substantial for the appreciation and cognition of ancient art and requires a thorough research beyond the scope of this study.

I. UNGLAZED WARES (11th–13th century)

The Bumiller Collection comprises 50 pieces of unglazed wares, that can be classified by their shape and surface treatment. Regarding morphological terminology I follow BALFET *et al.* 1989; the term jug is used in the common sense, it has a narrow opening to pour liquids and a handle. A bottle has a long narrow neck with a minimum diameter of one-third or less of the maximum diameter and no handle.

- 1.1 Coiled and slip painted jars (5 pieces)
- 1.2a–e Moulded jugs and bottles (16 pieces)
- 1.3 Moulded jug lids (7 pieces)
- 1.4 Jug with embossing (1 piece)
- 1.5a–f Sphericoconical vessels (21 pieces)

I.1 Coiled and slip painted jars (5 pieces)

The coiled pottery has closed shapes and was made for storage purposes (e.g. liquids, grain). It is a widespread type in Afghanistan, especially in the Herat region, and large amounts were found during a recently conducted archaeological survey and during the study of the Herat Museum collection (FRANKE 2016). Coiled and slip painted pottery is almost absent in the south and central provinces of Afghanistan, for example at the site of Lashkari Bazar (GARDIN 1963, 50, type 5) and Ghazni (BOMBACCI 1959, 52, fig. 58), and not very abundant in the ceramic corpus of the excavations in the medieval city of Bamyān (MARGUIER 2012, pl. III, fig. 4) or the more recently investigated site of Shah-i Gholghola (SIMÉON 2020b). We may therefore assume an origin of this type in the Herat region.

The use of a reddish-orange and/or brown slip for the spiral painted decoration has its origin in the Hephtalite period (6th–7th centuries) and is frequently found in the Central Hindu Kush and Northern Afghanistan (GARDIN / LYONNET 1987, 108–109, group 2, pl. 126).

The painting shows an abstract design that is created by combining various geometrical motifs, such as circles and spirals (BC 4093, 4094, 4095), hatched lines (BC 4094, 4095) and trellis patterns (BC 4799) with vegetal and floral motifs (BC 4093). Most common are spiral motifs and banded decorations. Similar patterns exist in woodwork or carved stucco decoration. A systematic typology of these designs that is also based on shape combined with morphology has been undertaken recently (FRANKE 2016) but questions of workshops and long-term chronology of these productions are still at a preliminary stage and fakes are still undetermined. Therefore, many objects from the Herat Museum are still doubtful.

The handles may be double stranded and braided (BC 4402, 4799), often with a thumb knob at the intersection point of the handle with the neck. Sometimes tiny angular pieces of turquoise glazed ware are inlaid on the vessel body at the junction with the handle (BC 4094, 4095, 4402).

Central Asian publications indicate that they may have been partly produced in South Tajikistan. This type of pottery was abundantly found in Southern Tajikistan excavations, in Tutkaul for instance (ATAHANOV 1978, pl. 43, 44, 46, hemispherical bowls). A few similar sherds with red slip decorations on a beige coloured slip base and mica in the fabric were found in the second excavated palace in Hulbuk, dated from the end of the 10th century until the middle of the 11th century (SIMÉON 2009, 83, pl. 61, type NG.19). Coiled painted pottery sherds were found in small quantities in Kyrgyzstan (ZADNEPROVSKIJ 1960, 225–226, table 48–49; ZADNEPROVSKIJ 1959, 158, pl. 11a).

In comparison, modest quantities come from Central Uzbekistan, for instance Samarkand, identified early on by VIATKIN (1926, 37–38) and studied in later investigations (SHISHKINA 1979, table 36; SOKOLOVSKAIA 1995, pl. 61), generally dated to the 12th century. More recently this pottery was also found in Kultepa near Zamin with a clear stratigraphic context dating to the 12th century (GRITSINA *et al.* 2014, 73, 87, fig. 71, 97a).

In other regions of the Islamic world, coiled and slip painted pottery also occurs and is variously called ‘pseudo-prehistoric ware’, ‘Ayyubid-Mamluk type’ or ‘hand made geometrically painted ware’ (HMGPW). These types were widespread in Jordan, Palestine, Southern Syria and Iraq between the 11th and 13th centuries (JOHNS 1998). In what way these Near Eastern types are linked to Central Asian and Afghan productions needs further investigation.

Coiled and slip painted wares appeared on the art market in the years following the collapse of the Soviet Union (KALTER / PAVALOJ 1997, 151 show a very similar jar to the ones from The Bumiller Collection). At Sotheby’s a large jar similar to BC 4402 and BC 4799 was sold in 2005 (lot 89).

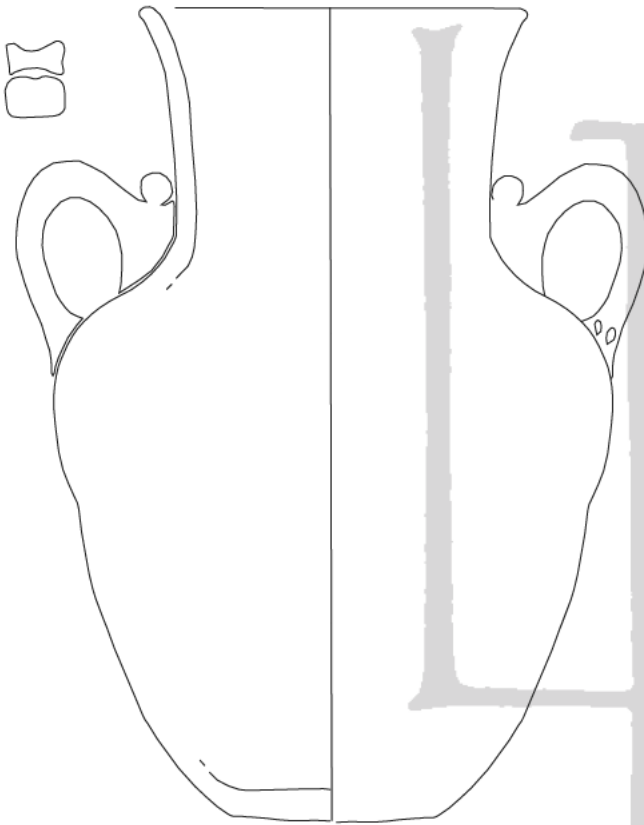

BC 4093

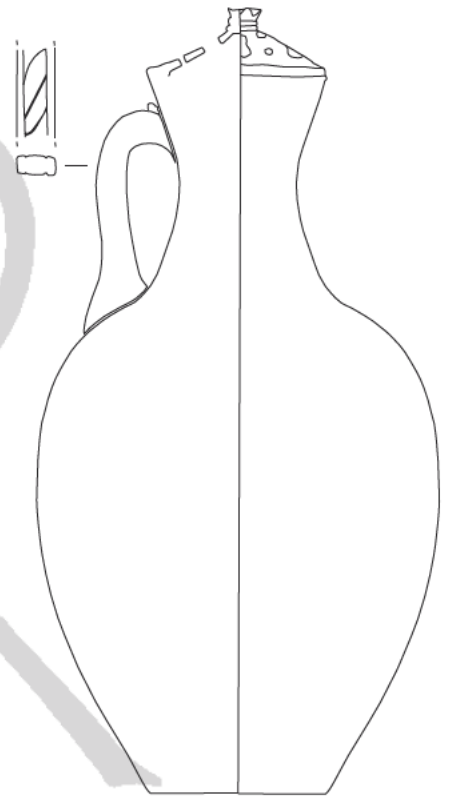

BC 4095

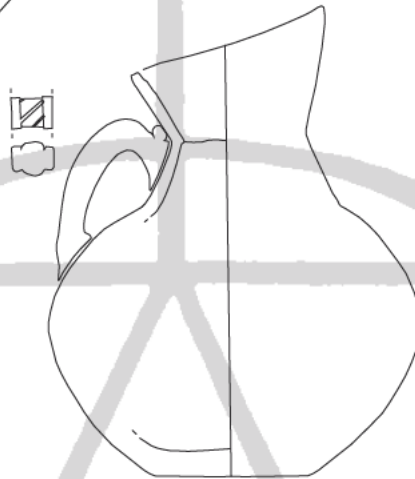

BC 4799

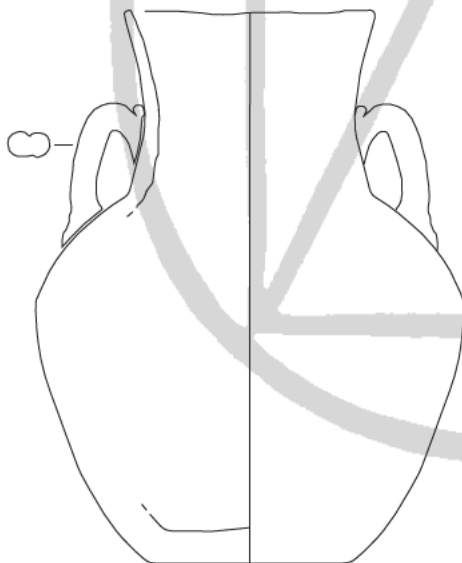

BC 4094

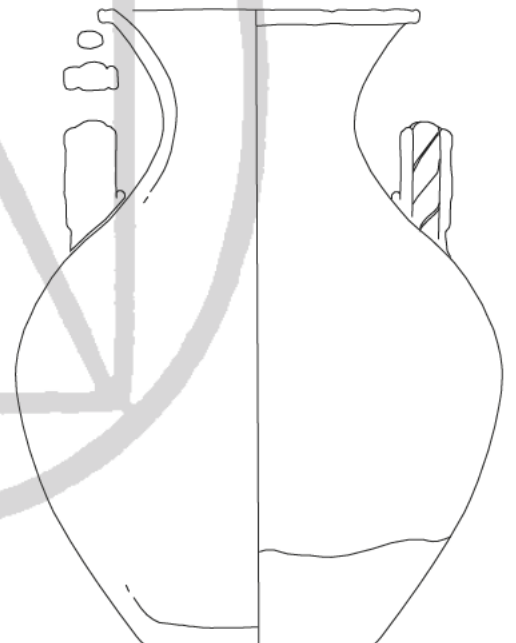

BC 4402



Jar with an everted rim and large mouth BC 4093
earthenware, coiled, with slip painted decoration, unglazed
probably Northwestern Afghanistan, Herat (?)
11th–12th century
h. 60.5 cm, d. max 41 cm
base chipped and restored
Provenance: reportedly from Afghanistan, 2000

Red fabric, buff slip outside, pink slip inside and slip painted decoration in brown colour. Double loop handles with ridges attached to the shoulder and upper part of the body of the vessel. Small pierced holes form a semi-circle around the join of handle and body. These might originally have been filled with coloured glass or glazed ceramic pieces.

Jar BC 4094
earthenware, coiled, with slip painted decoration, unglazed
probably Northwestern Afghanistan, Herat (?)
12th century (?), possibly recent production (20th century)
h. 41 cm, d. max 32 cm
one handle restored
Provenance: reportedly from Afghanistan, 2000

Buff fabric, numerous black angular inclusions, no traces of usage. The vessel has a large neck with a flared rim. It could be related to a specific purpose, possibly for fetching water. The angular shaped double handles are attached to the neck and have small applicated thumb stoppers at the top. A sherd with turquoise glaze is inserted on the bottom of the handle as in the jug BC 4095. The inside shows traces of turning and might suggest that the vessel was finished on a potter's wheel (turn table/ tournette). The painted decoration shows geometric and scroll motifs.

Undetermined item BC 4095
earthenware, coiled, slip painted, unglazed
probably Northwestern Afghanistan, Herat (?)
12th century (?), possibly recent production (20th century)
h. 53 cm, d. max 30 cm
unrestored
Provenance: reportedly from Afghanistan, 2000

Buff fabric with an unusual shape: it looks like a jug but the mouth is sealed by a lid with small circular holes and a trifoliate button. This functional incoherency contradicts the visual appearance of a storage jar and indicates another function. It could be the misinterpretation of a contemporary craftsman copying ancient models without understanding their function properly. The small opening recalls a sprinkler, so this object may also be a *kundika* or at least be inspired by these Buddhist water sprinklers (see also the comments on BC 2895 and 5731).

The round bottom suggests the use of a base ring. The black slipped decoration under a buff finish was applied with a brush. Little turquoise glazed sherds are inserted in the braided handle as is the case for BC 4799 and 4094. The painted motifs are mainly tendrils and stylized flowers on a hatched background. Here too, the dark brown slip painting on a whitish background resembles some suspicious complete pieces that only turned up on the art market. Some more jugs in The Bu-miller Collection were excluded from this catalogue because of similar inconsistencies.

Jar BC 4799
earthenware, coiled, with slip painted decoration, unglazed
probably Northwestern Afghanistan, Herat (?)
11th–12th century
h. 37cm, d. max 28 cm
unrestored, parts rubbed off, long crack in the inner part
Provenance: reportedly from Afghanistan, 2012

Buff fabric, with mica and little black angular inclusions. Braided single handle like BC 4095. White slip painted spirals and hatched lines on a red-brown and black slip associated with incised and stamped decoration near the flat base. At least three different slips were used in the workshop that produced this jar: red-brown, white and black.

The technique of finishing an unglazed object with a very pale and almost transparent finish over a dark coloured slip appears on glazed pottery at the end of the 11th century. Was this technique first used on unglazed wares before transferring to glazed wares? Archaeological data from Afghanistan and the current state of research on this type of unglazed pottery do not allow for a more detailed chronology to authoritatively answer the question. See as well comments about chronology with the previous jar BC 4095.

Jar BC 4402
earthenware, coiled, with slip painted decoration, unglazed
probably Northwestern Afghanistan, Herat (?)
11th–12th century (?)
h. 47 cm, d. 36 cm
traces of attrition, half neck partly restored
Provenance: reportedly from Afghanistan, 2002
References: Behzod National Museum (Dushanbe, Tajikistan)

Buff fabric, irregular surface but smooth slip. The neck seems to be a wheel-thrown addition to the coiled body as indicated by production traces. Contours of the painted motifs are in a dark brown slip while the forms are filled with coloured red slip. The colours of the painted decoration have faded. The braided handle is again decorated with inlays of little turquoise-coloured sherds, in association with 'pastillage' decoration between the handle and the body.

1.2 Moulded jugs and bottles (16 pieces)

Usually the fabric of the moulded jugs and bottles is buff, only three pieces have a fine and grey fabric (BC 2895, 4765, 5733). Similarly shaped bottles with a grey fabric are characteristic of Turkmen productions. All the jugs were moulded in two parts, then joined using barbotine and refinished on the potter's wheel leaving more or less clean horizontal traces in between. In general, the moulded lower part includes the base (BC 2414, 5730 and maybe BC 2718). The upper part is completed with a wheel-thrown neck; the handle is added afterwards and covers small parts of the decoration. The fine moulded designs suggest, in some cases, the use of metallic moulds rather than earthen moulds.

Moulded jugs were found in nearly all excavated Central Asian, Iranian and Afghan medieval cities at levels dating from the 10th to the 13th centuries. They were produced in large quantities in many workshops, as attested by numerous moulds found in Merv, Istakhr, Hulbuk, Nishapur, Pajkend, Termez and Samarkand, to name but a few.

The question is: which are the decorative elements that distinguish this type. Bead motifs often fill the background. Dotted ribbons and stippling of the background often surround pattern fields or ribbons, also common in the technical and decorative repertoire on metal artefacts and textiles. Little dots, stars and flower motifs are characteristic of the earthenware moulded pottery, the epigraphic decoration is generally set against a background of bead motifs (dotted, or ringlets) which shows at least a similar aesthetic taste among this kind of moulded jug. Different artistic media show similar patterns as well. The wall paintings in the Georgian church in Svaneti (dated 1140) for example show local notables wearing Arabic *tiraz* clothes with a band worn on the upper part of the arm adorned with pseudo-epigraphic writing on a dotted background.¹

The most important comparative archaeological corpus for moulded jugs related to Central Asia and Afghanistan is the one from Lashkari Bazar (GARDIN 1963, drawing on pl. 1, plates V–XII dated 11th–12th centuries). This type of pottery was very popular and widely produced in the 40 workshops identified within Central Asia so far (SIMÉON 2012, 19–20). Unfortunately, only sparse evidence of the production procedures, such as pieces of moulds and wasters from these workshops, were collected and published, except for Merv in Southern Turkmenistan (LUNINA 1962, 298–345, dated to the 11th–13th centuries) and more recently Hulbuk in Southern Tajikistan (SIMÉON 2009, 54–59, type NG2, pl. 2–13 dated to the second half of the 10th century).

The Nishapur excavations brought a relatively small number of moulded sherds of these jugs to light (WILKINSON 1973, 291–294 and pl. 355–360), among them one clear parallel in shape to a piece in The Bumiller Collection with

a short neck (subtype 1.2a). Unfortunately, the Nishapur assemblage of this type of ware is too fragmentary to show any regional or local patterns. For a complete overview of archaeological findings in Turkmenistan (Asadabad, Iarty Tepe, Nisa and others), Uzbekistan (Tashkent, Termez, Ahsikent, Karabulak, Samarkand, Ribat-i Malik) and Northern Iran from the 10th–13th century see SIMÉON 2009, 55–57. Research track of variants from Northern Iran or Caucasus should be investigated (subtype 1.2c).

Comparing the Bumiller pieces to this archaeological corpus and these published sources shows that they all belong to specific subtypes from medieval Afghanistan common around the 12–13th centuries. GARDIN presented a preliminary classification of moulded ceramic decoration based on the abundant finds in the Balkh excavations (GARDIN 1963, 23–50). In spite of his systematic approach, the corpus was not well defined typologically and chronologically, as it was dissociated from fabric and shape. In this respect its implementation is still difficult for fieldwork or museum research.

In the collection four subtypes can be distinguished:

- 1.2a Jugs with short neck (4 pieces)
- 1.2b Jugs with conical neck (6 pieces)
- 1.2c Bottles (4 pieces)
- 1.2d Jugs with bull-headed spout (2 pieces)

1.2a Jugs with short neck

Jugs of this first type are strongly related to Iranian fritware pottery known as white ware (ATIL 1973, 39, No. 13, Freer Gallery). The typical shape has a slightly angular and carinated shoulder (see BC 5732) and a short and flaring neck, although moulding is not a suitable technique for this shape. The base is often raised as in BC 949. In some cases the lower part of the base is wider than the upper part, which gives a slightly carinated profile (not bulbous). These wares occur in the 12th century in Iranian context.

Jug BC 949

moulded earthenware, unglazed

Afghanistan, Northeastern Iran or Southern Central Asia

12th century

h. 11 cm, d. max 14 cm

neck and handle are missing, broken edges burnished

Provenance: reportedly from Afghanistan, 2008

References: GARDIN 1963

Pinkish fabric with a buff surface. The wheel thrown neck is missing. It probably broke off and the jagged edge was polished for resale on the art market. The shoulder is decorated with Arabic inscriptions with wishes of well-being for the owner: *al-'izz wa-l-iqbāl wa-l-daula wa-l-salāma wa-l-sa'āda* ("Glory,

¹ Personal communication with Barry Flood and Koshoridze, May 2016, Berlin.

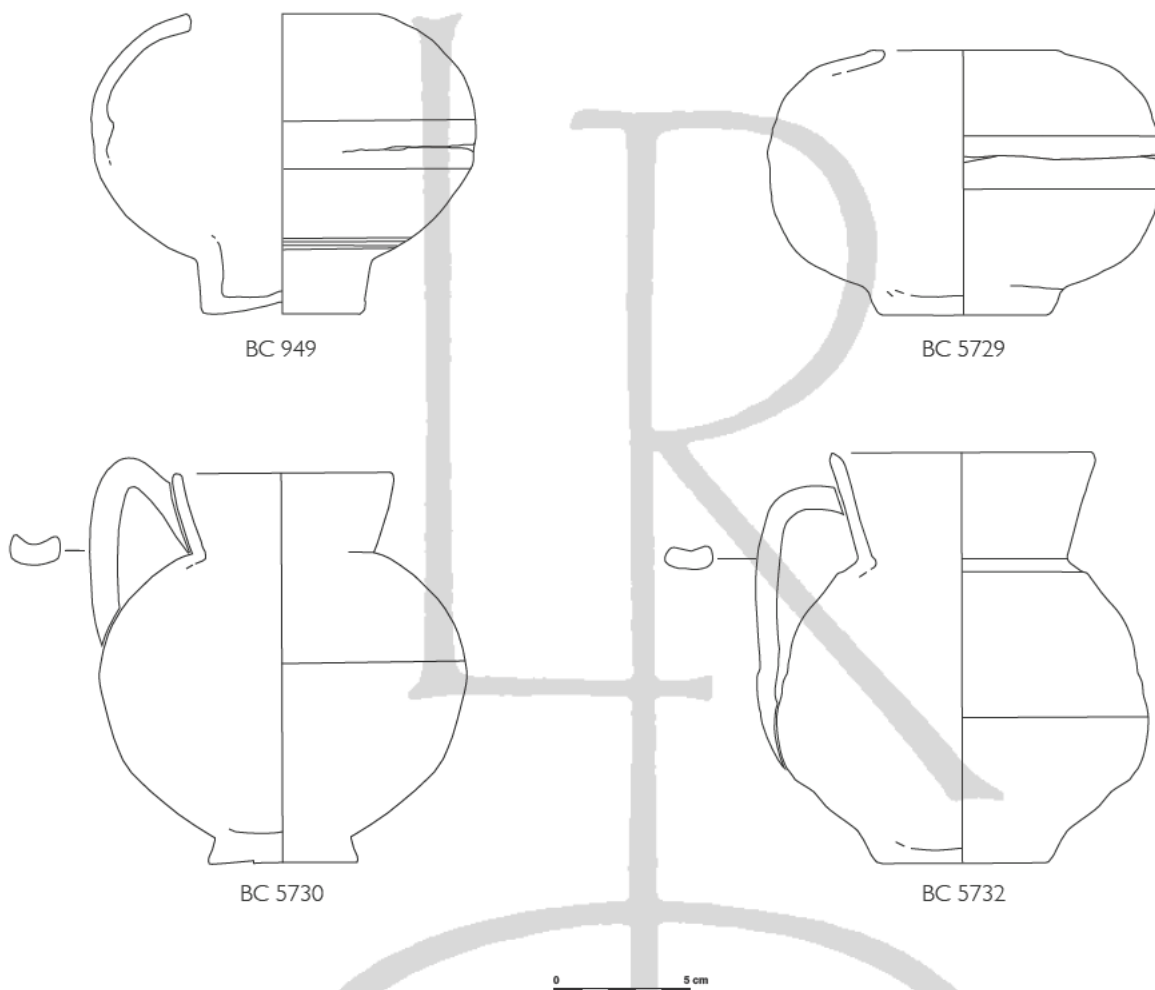

prosperity, dominion, safety and happiness”). On the backside of the base circles are visible, as on BC 946 in chapter 1.2e and on some bases of moulded pottery from Lashkari Bazar (GARDIN 1963, pl. IX, No. 79 and 84).

The lower body part is gadrooned and incised with a herringbone pattern reminiscent of designs on spheroidal vessels of the 12th century. A similar decoration of alternating gadroons and flower medallions appears on the inner part of a moulded jug coming from Lashkari Bazar and belongs to the 11th or 12th century (GARDIN 1963, pl. VII, No. 46).

Jug BC 5729
 moulded earthenware, unglazed
 Afghanistan, Northeastern Iran or Southern Central Asia
 12th century
 h. 10 cm, d. neck 6.5 cm, d. max 15 cm
 unrestored
 Provenance: reportedly from Afghanistan, 2011

Yellowish-greenish fine fabric, with a uniform finish, moulded in two parts (see head chapter). The piece seems to represent the original shape without a handle, the patina is plain and the

vessel probably did not have a neck. The shoulder is decorated with a succession of medallions in heavy relief with stylized ducks, the inner body shows a repetition of vertical bands with twisted ribbons.

Jug BC 5730
 moulded earthenware, unglazed
 Afghanistan, Northern Iran or Southern Central Asia
 12th century
 h. 14.5 cm, d. 13.5 cm
 neck restored
 Provenance: reportedly from Afghanistan, 2011
 References: MOULIÉRAC 1999, WATSON 2004a, UNGER 1992

Greenish fabric. Only the upper part of the vessel is moulded while the base is wheel-thrown.

A central circular medallion shows a head wearing a crown with pointed ends on either side like the tricorne hats of the Mongols (STILLMAN 1954). The head is surrounded by an inscription that is difficult to read. There are four larger circular and pentagonal stamps with moulded zoomorphic decoration (birds face-to-face and an undetermined quadruped, two lions

facing each other). They are unique among the corpus of jugs and probably not contemporaneous with the other moulded vessels of the set. The stamped motifs are similar to those found on bath scrapers (MOULIÉRAC 1999, 25; WATSON 2004a, 116) and are similar to the stylized animals of the tiles collected in Ghazni (see for instance UNGER 1992, 100–101, 103, fig. 27,6).

An angular object was used to imprint a design at the join of the two-piece vessel, a technique probably used to enhance the two parts at the join of the body. The proportions of this jug, its rounded shape, short neck and stamped body and join marked with a central strip are identical to a jug kept at the Kuwait Museum (WATSON 2004a, 110, cat Ab. 5) as well as to the jug signed by *Muhammad Ahmad al-Sarraj* in the British Museum (LANE 1956, pl. 36, A). Three similar jugs were also found during the Nishapur excavations (WILKINSON 1973, 358 nos. 161–163, upper part with epigraphy on a dotted background). Another similar jug coming from Afghanistan is kept in the Kuwait National Museum (WATSON 2004a, 110, Cat. Ab. 5). Further parallels, by morphology, size and decoration layout, can be found in a jug in the Frankfurt Museum (MÜLLER-WIENER 1996, 69, No. 59) that probably comes from the same workshop.

Jug BC 5732

moulded earthenware, unglazed
Afghanistan, Northeastern Iran or Southern Central Asia
12th century
h. 15.30 cm, d. neck 10 cm, d. max 14 cm
neck partially restored, some repaint
Provenance: reportedly from Afghanistan, 2011

Fine buff-greenish fabric, moulded in two parts with a bigger mould used for the lower part resulting in a specific asymmetric profile. Circular stamped frieze of birds (peacocks?) in the upper part and almond-shaped vegetal motif in the lower part. The stamped flower on the underside of the base could be a workshop mark. The jugs and bottles analysed in the recent study of the Islamic ceramics from Ghazni belong to a very different type with a high foot and tall neck (FUSARO 2014).

I.2b Jugs with conical neck

Jug BC 947

moulded earthenware, unglazed
Afghanistan, Northeastern Iran or Southern Central Asia
11th–12th century
h. 17.5 cm, d. 13 cm
neck restored
Provenance: reportedly from Afghanistan, 2008
References: GARDIN 1963

Buff fabric and soft surface with a wheel thrown neck. The triangular ridged handle is unusual. It has circular imprint marks on the bottom as does BC 949 (chapter 1.2a) and the repeated motif on the inner part could be a stylized fish. The gadrooned upper part of the body alternates with four feline heads oddly turned upside down. This twisted position could be deliberate if this small jug is in fact a beaker, following a hypothesis postulated by Kervran (personal communication 2008). In that case the drinker would see the motif at the proper angle and possibly the vessel also had an apotropaic function. Another explanation is the erroneous use of a base mould for the upper part of the jug. Shape, concave base and conical neck seen in all the jugs of the present sub-type (1.2b) are very similar to two jugs found in Lashkari Bazar (GARDIN 1963, type 4, pl. 1, No. 37–38).

Jug BC 948

earthenware, unglazed
Afghanistan, Northeastern Iran or Southern Central Asia
12th–15th century (?)
h. 14.5 cm, d. max 12.5 cm
unrestored, traces of abrasion over the neck, handle missing
Provenance: reportedly from Afghanistan, 1995

Grey fabric with fine with a high proportion of mica. Wheel thrown neck with a cutting edge. The lower part of the jug is decorated with a frieze of stylized ducks. Shape and design hint to the 12th century and ongoing post-Mongol period production.

Jug BC 5574

moulded earthenware, unglazed
Afghanistan, Northeastern Iran or Southern Central Asia
11th–15th century (?)
h. 20 cm, d. 17 cm
upper part of the neck and handle restored
Provenance: reportedly from Afghanistan, 2011
References: POPE 1939, SIMÉON 2009

Fabric undetermined, heavy and thick body. Water-filter with five holes. The flared neck is marked, a feature equally found on jugs from Hulbuk (SIMÉON 2009, pl. 2, fig. 2) and Lashkari Bazar (GARDIN 1963, pl. VI, 35–37). The inscription frieze on the shoulder is superimposed with repetitive stamped rectangular fields, which make it difficult to decipher. The body shows a repetition of the shortened blessing formula *lī-šā* in floriated and cursive script, an abbreviation for *lī-šāḥibibī* (“to its owner”). Similar abbreviated wishes are attested on glazed Champlévé pottery of the 11th and 12th century (POPE 1939, pl. 604A and 615A). The jug has imprints under the base like many of the moulded jugs in The Bumiller Collection.

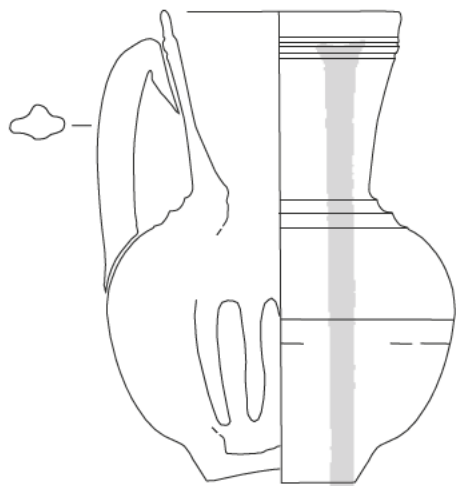

BC 947

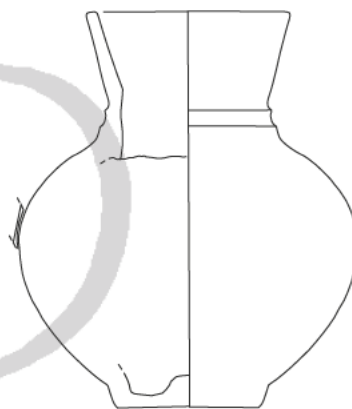

BC 948

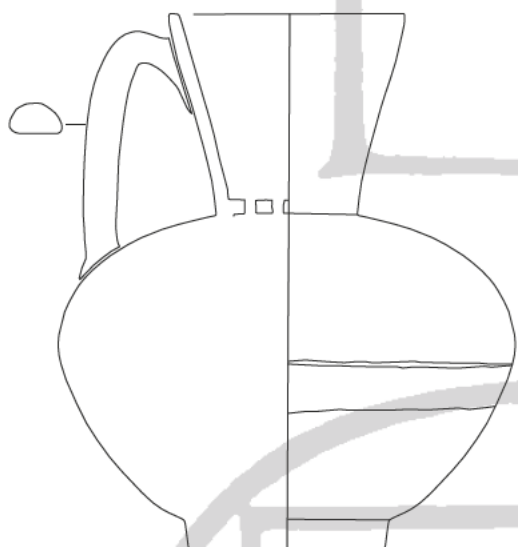

BC 5574

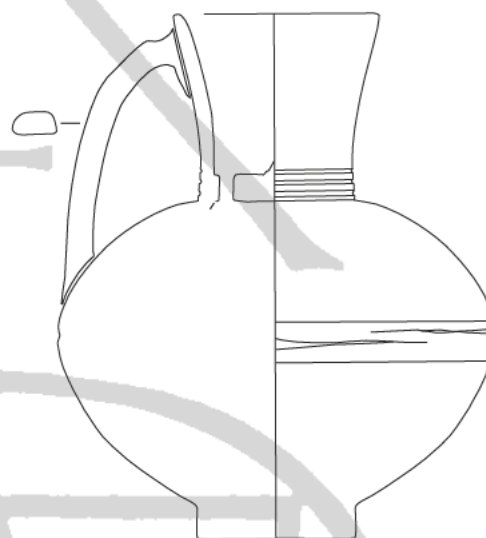

BC 4765

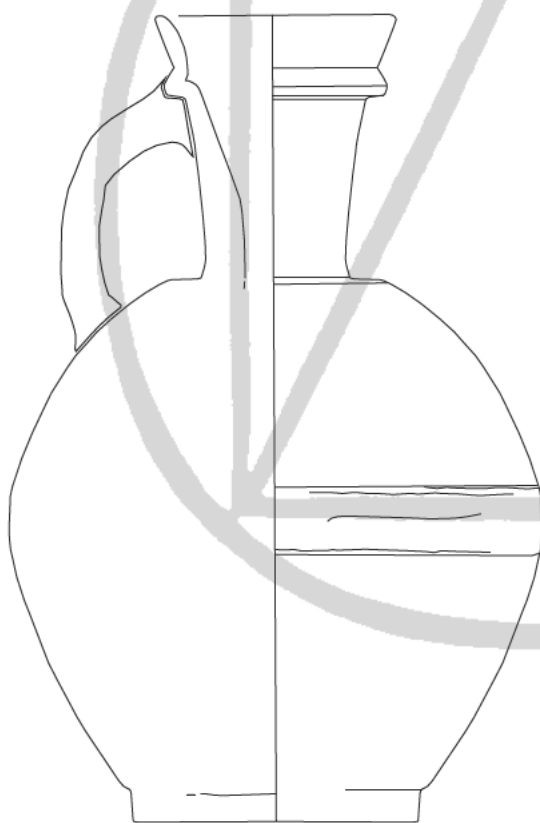

BC 2718

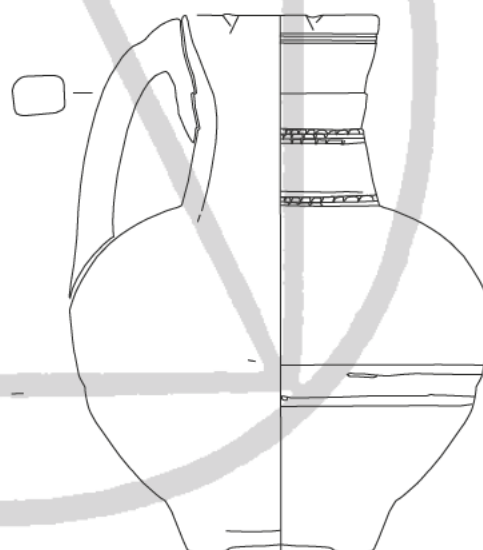

BC 946



Jug BC 4765

moulded earthenware, unglazed
 Afghanistan, Southern Central Asia, Turkmenistan (?)
 11th–15th century (?)
 h. 19.5 cm, d. 16 cm
 handle completely restored, upper part of the neck restored
 Provenance: reportedly from Afghanistan, 2008

Grey fabric, the neck is wheel thrown. Filter with six circular holes and a triangular central bud, similar to BC 5574. The decoration on the upper part of the body is anthropomorphic; a human face with prominent cheekbones. Reversed “S”-motifs are usually found on this kind of moulded vessels. Stamping marks on the underside of the base consist of a double-lined ribbon design of dots.

Jug BC 946

moulded earthenware, unglazed
 Afghanistan, Northeastern Iran or Southern Central Asia
 15th–18th century (?)
 h. 20 cm, d. 15 cm
 unrestored, surface burnished and abrasion traces on the rim
 Provenance: reportedly from Afghanistan, 2008
 References: KALTER / PAVALOJ 1997, SIMÉON 2009

Grey fabric, slightly greenish, heavy handle. Decorative incisions on the neck made with a sharp tool identical to the piece BC 1282. These incisions and the rim have small cuts as observed on some necks of moulded ware found at Hulbuk (SIMÉON 2009, pl. 4, fig. 7). A very similar piece in shape and decoration is kept in the Linden Museum in Stuttgart (KALTER 1987, 144, fig. 249). Foliated motifs in almond shapes. This type could be of post-Mongol production. For the traces on the base see the comment on piece BC 949 in chapter 1.2a.

Jug BC 2718

moulded earthenware, unglazed
 Northern Iran or Caucasus
 12th–14th century (?)
 h. 30 cm, d. 20 cm
 unrestored
 Provenance: reportedly from Afghanistan, 1995

This jug is different from the rest of the corpus: it is bigger in size and the body is very thick and strong. The stamped decoration on the upper part is also particular: opposing peacocks frame a stylized palmette whose inner decor is composed of drop motifs. Two relief lines underline the flat base.

No parallels occur in the excavated material available from Central Asia. Most of the comparable pieces are decorated with felines divided by a stylized palmette and come from the art market (e.g. Sotheby's 27 April 1995, No. 271, 34.5 cm height).

I.2c Bottles

Bottle BC 1282

moulded earthenware, unglazed
 Northeastern Iran or Turkmenistan
 12th–13th century (?)
 h. 24 cm, d. 15 cm
 unrestored, the broken neck is glued
 Provenance: reportedly from Afghanistan, 1988
 References: LUNINA 1962, SIMÉON 2020a

Grey fabric. This shape is similar to bottles without a handle. The vessel is decorated with a row of three elaborate epigraphic medallions in foliated kufic script followed by one medallion showing two quadruped animals on both sides of the central *lām-alif*. The epigraphic medallions (in Arabic or Persian) was stamped three times and superimposition makes it difficult to read, but it could be a patron's name. The stylized ibex (?), a motif quite common on Lashkari Bazar moulded pottery (GARDIN 1963, 46, fig. 42a), on the upper half of the jug contrasts with the precision of the epigraphic medallion on the lower part of the bottle's body. The lower part of the body shows embossed medallions similar to those on Ghaznavid period pottery (cf. ceramics from Balkh in SIMÉON 2020a). Similar embossed medallions can be found on the shoulder of contemporaneous large jars as well.

Some bottles of a grey fabric, similar in size and shape as well as design (especially the stylized ibex), were found at the Merv excavations and dated to the 12th–13th centuries (LUNINA 1962, 308, pl. 42, pl. 51).

Bottle BC 2414

moulded earthenware, unglazed
 Afghanistan, Northeastern Iran or Southern Central Asia
 12th century or recent production (20th century)
 h. 13 cm, d. max 15 cm
 Provenance: reportedly from Afghanistan, 1993

Pinkish fabric, buff surface with blackish oily patina. The profile shows a slight difference in size between upper and lower body and a large central strip. Originally this jug was equipped with a filter. The upper part of the body is decorated with indeterminate quadruped animals. The lower part of the body has repetitive medallions with stylized long-necked birds.

The inner part is covered with repetitive overlapping stamps which is unusual. The motives on this bottle are in very low relief, strangely eroded in both parts. The foot was roughly shaped on a turn table suggesting that the potter was unfamiliar with the moulding technique. Also the fact that the bottle was bought with a bull-headed spout, with small drips of green glaze on its horns, that was clearly added from another vessel, may define this object as a forgery.